

Comprehensive  
Electromagnetic  
Solutions

# FEKO



QUARTERLY: September 2007

### Inside this issue:

- An overview of new features in FEKO 5.3.
- Non-radiating network analysis
- MLFMM near-field calculation
- Optimisation
- Geometrical Optics
- New FEKO website

## Features in this issue

**FEKO 5.3 was released in July 2007, along with a brand new website.** This FEKO release included many improvements to existing features and also some significant new capabilities. This quarterly is dedicated to highlighting major upgrades in FEKO 5.3 and a short introduction to the new website technology. As always, your comments on the quarterly are welcome. If you would like to contribute an article, please send it to [quarterly@emss.co.za](mailto:quarterly@emss.co.za).

## Release of FEKO Suite 5.3

The FEKO development team has spent many hours to develop new functionality and to improve existing tools for the release of FEKO 5.3. Their hard work culminated in the latest release of FEKO in July 2007.

Major elements of this release include:

- A complete redesign of OPTFEKO, the optimisation engine of FEKO, with full integration into CADFEKO and POSTFEKO.
- Implementation of general non-radiating network analysis functionality.
- Implementation of Geometrical Optics (GO) as a technique for the simulation of electrically large dielectric structures.

Exciting new features in the general user interface and CAD geometry editing and creation environments include:

- Selective importing of existing CADFEKO models, i.e. any combination of geometry, mesh, media, variables and solution components may be imported into CADFEKO from existing CADFEKO models.
- Points list importing from a text file. Users can define curves with complex geometries by computing the coordinates of points on a curve in their 3rd party application of choice and simply importing these point coordinates into CADFEKO.
- Porting of POSTFEKO to the 64-bit x86\_64 platforms for both Windows and Linux. This feature greatly improves POSTFEKO's ability to work with large models and extensive results datasets.

In the kernel several improvements have been made, including:

- MLFMM can now rapidly compute near-field solutions.
- Efficiency of the parallel MLFMM has been significantly improved.
- The UTD now allows multiple plates to connect to the same edge.
- Impressed current source and loads in the FEM region of a model.

The FEKO team invites all users and interested parties to visit the FEKO website and read the release notes for more detailed lists of improvements. We are confident that the latest release of FEKO will improve the simulation experience for all our users.

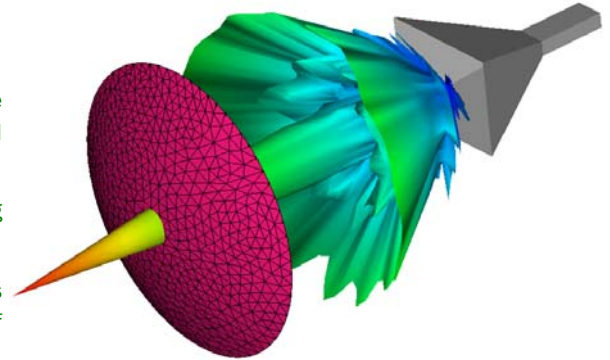

*MoM /GO computation of far-field radiation pattern of a horn radiating through a dielectric lens.*

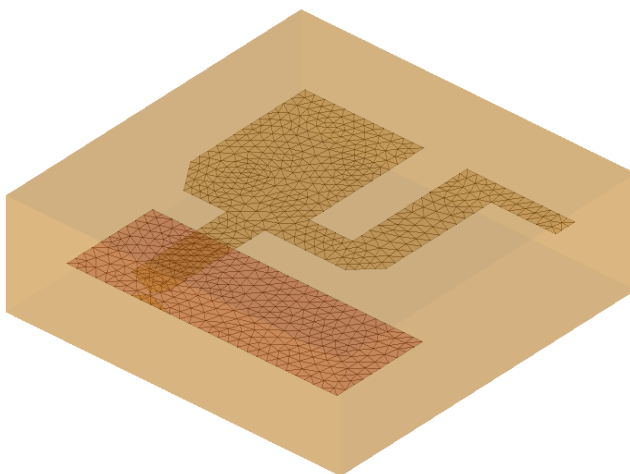

*UWB antenna with a load in the FEM region of the model.*

**“Circuit parameters of smaller element blocks may be cascaded and combined with FEKO geometry.”**

## General Non-Radiating Networks

Designers often require the simultaneous modeling of radiating structures and the linear circuits that connect with them. An example of such a model would be a transmitting antenna coupled to a circuit consisting of amplifiers, filters and matching networks. Until now the major stumbling block for such simulations was that the linear circuits could either not be simulated using electromagnetic simulation software or that the circuits had to be discretised using very small elements, resulting in prohibitively large memory requirements and long runtimes.

This problem is solved with the introduction of non-radiating networks in FEKO Suite 5.3. Complex geometries may be modelled in separate simulations and the S-, Z- or Y-parameters can be extracted for separate geometry entities. These circuit parameters may then be cascaded and com-

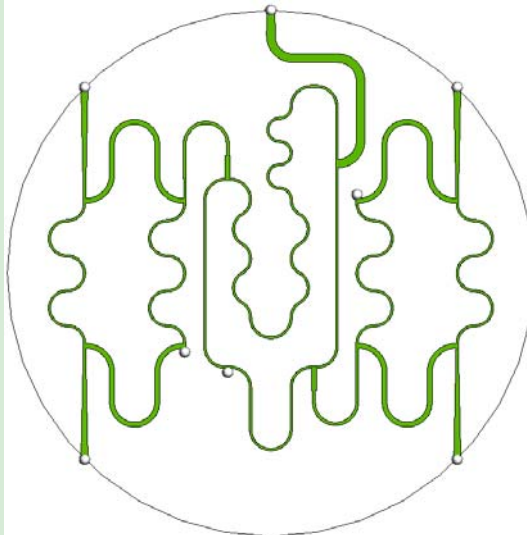

*Feed network for a quadriflar helix.*

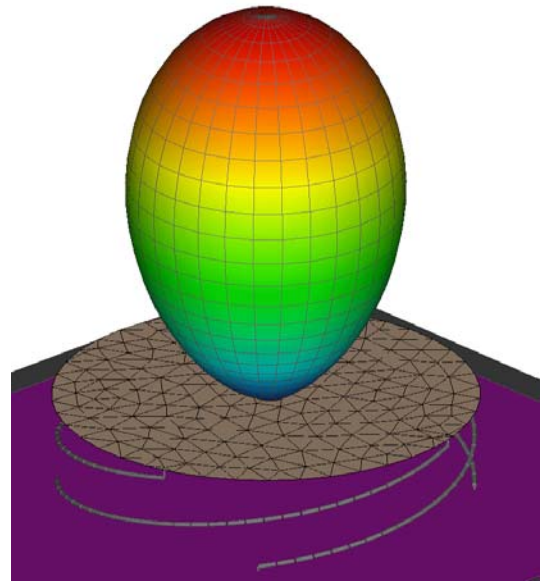

*Radiation pattern of a quadriflar helix with non-radiating network feed.*

binated with FEKO geometry. The individual circuit parameter element blocks will, however, be simulated without field coupling between them.

A typical example of how this technology may be applied is to simulate the quadriflar helix antenna that won S.J. Marais the FEKO student competition in 2005. The feed network was simulated to obtain its S-parameters, which were then used as a non-radiating network to feed the quadriflar helix. Runtime decreased by 99% and the memory requirement decreased by 98% when the feed network was modelled using a non-radiating network, rather than with a full-wave simulation. Full moment method simulation results agreed very well with this application of non-radiating networks.

**“FEKO Suite 5.3 allows users to use the MLFMM for the efficient computation of near-fields in complex environments.”**

## MLFMM Near-Field Calculation

The MLFMM has established itself as an indispensable tool for the solution of electrically large problems. The traditional MLFMM implementation is still used to compute the currents on the structure, but classical integration routines are slow when computing near-fields in models with large objects and many observation points. FEKO Suite 5.3 allows users to use the MLFMM for the efficient computation of near-fields in complex environments. In the test example a 2D near-field cut,

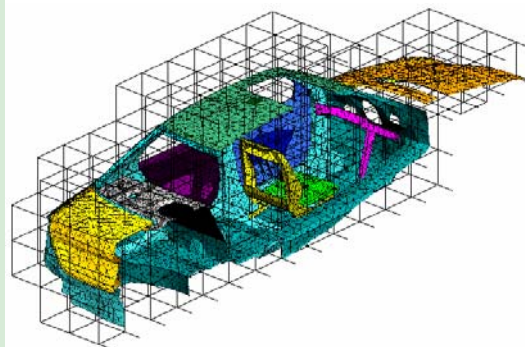

*Traditional MLFMM computation of currents.*

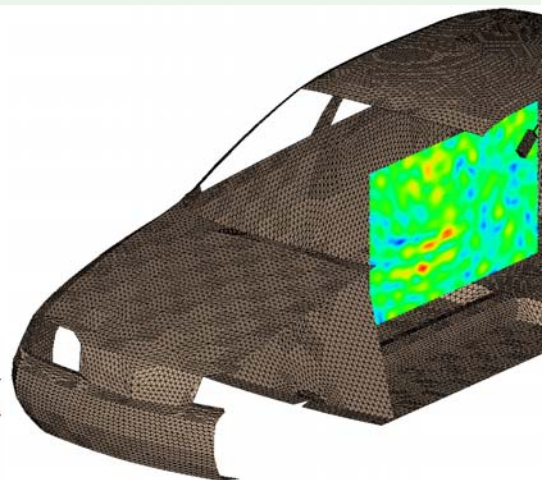

*Near-fields computed in a car.*

consisting of 1581 observation points was computed for a vehicle with 95908 unknowns. The MLFMM near-field calculation reduced the computation time to 4.7 % of the time required for the original simulation! The computation for models with more unknowns should speed up even more.

## Optimisation

**FEKO Suite 5.3 introduces new and significantly improved optimisation functionality.** These OPTFEKO features range from more optimisation techniques to improved GUI integration and goal function definition possibilities. This article explains some of the new features while optimising a Yagi-Uda antenna for minimum backlobe radiation and maximum boresight gain.

### GUI integration

The new optimisation features have been fully integrated into CADFEKO and POSTFEKO and any model that was constructed with variable parameters can be optimised. In Yagi-Uda example the length of the elements and the spacing between them are the variable parameters.

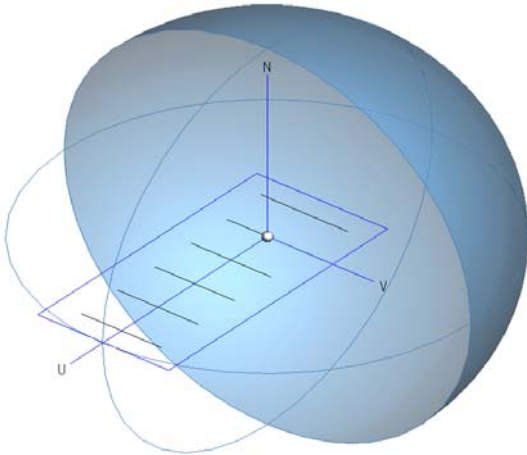

Yagi-Uda antenna with radiation pattern to be optimised.

### Goal function definition

Goal functions can be defined by combining the requested output parameters of the simulation into a single goal or multiple goals that the optimiser will strive to achieve. In Yagi-Uda example the boresight gain is maximised and the maximum gain in the backlobe is minimised. Goals can be given different weighting to specify each goal's importance relative to the other goals. In this case the goal of minimising the backlobe radiation was

given twice the weighting of the boresight gain maximisation.

### Optimisation techniques

The new OPTFEKO component provides the following optimisation methods:

- **Grid search** where the optimisation parameters are varied linearly on a predetermined grid between their minima and maxima and the optimum solution is reported.
- **Simplex Nelder-Mead (NM)** which is a local or hill-climbing optimisation method.
- **Particle Swarm Optimisation (PSO)** which is a global search population based stochastic evolutionary computation technique, based on the movement and intelligence of insect swarms.
- **Genetic Algorithm (GA)** which is also a global search population based search method, based on the Darwinian principles and concepts of natural selection and evolution.

NM, PSO and GA specific parameters (e.g. population size, number of iterations, error treatment and termination) are all automatically selected by FEKO so the user does not need a detailed understanding of these methods to use them effectively.

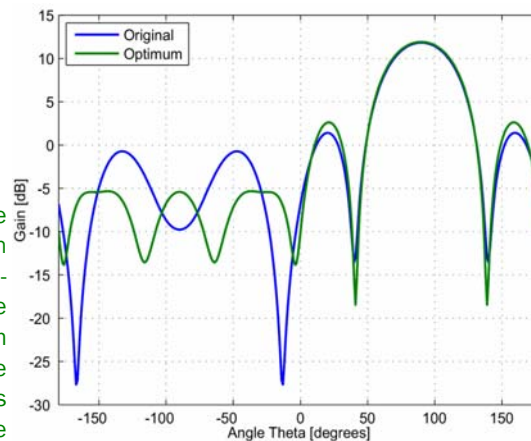

Original vs optimised radiation patterns.

## Geometrical Optics (GO) for Large Dielectric Object Modelling

**FEKO 5.3 introduces Geometrical Optics (GO) as a method for the modelling of large ( $> 20 \lambda$ ) dielectric objects.** The solution options that are currently in FEKO (MoM, FEM, MLFMM, dielectric PO) support such structures, but do not scale well.

GO is a ray-based technique, much like UTD, but models the reflection as well as transmission of rays that interact with dielectric objects. Typical applications of the GO will include lenses and radomes.

The GO implementation requires the surface of the dielectric object to be

meshed into triangles, just as it would have been for the MoM or PO. This enables the user to follow familiar modelling procedures and simply select the GO as solution method for a given surface. It also allows the user to easily switch between different numerical methods for the modelling of a dielectric object.

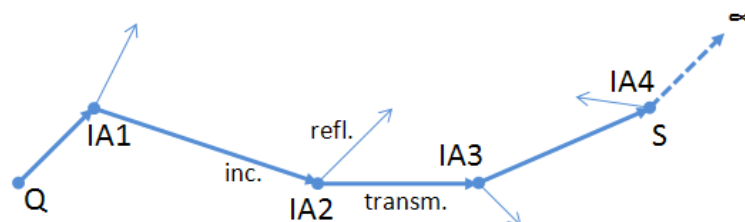

Ray-launching and dielectric boundary interaction modelling.

**“The new optimisation features have been fully integrated into CADFEKO and POSTFEKO and any model that was constructed with variable parameters can be optimised.”**

**“GO is a ray-based technique, much like UTD, but models the reflection as well as transmission of rays that interact with dielectric objects.”**

## New FEKO Website

A new FEKO website was released in July 2007. The site contains all the features of the previous site, but provides a much more manageable and user friendly environment. Prospective users will still be able to find information on FEKO's technical features, licensing policy, news, exhibition events etc. and existing customers will still be able to verify and modify their personal details on the FEKO database and download the latest FEKO binaries and updates.

The new FEKO website was developed with the vision of becoming a source of knowledge for all kinds of simulation projects that span various industries that use FEKO or possible applications of FEKO. This knowledge base is easily managed and extended by all members of the FEKO engineering, development, support and marketing teams to deliver as broad a content base as possible.

**FEKO**  
Comprehensive EM Solutions  
field computations involving objects of arbitrary shape

You are here: Home | Applications | Industries | Product Info | Sales/Evaluation | Log in

**Quick Links**  
FEKO at a glance  
Free Evaluation

**News**  
Suite 5.3 release 2007-09-01  
FEKO Distributor Conference 2007 2007-05-14  
FEKO at AGES 2007 2007-03-20  
More news...

**Upcoming Events**  
ISAP 2007 Niigata, Japan, 2007-09-20  
ISMOT 2007 Brest, France, 2007-08-22  
EMC Zurich Munich, Germany, 2007-09-24  
Upcoming events

**Introduction to FEKO**  
FEKO is a software suite for the analysis of a wide range of electromagnetic problems. Application include EMC analysis, antenna design, microstrip antennas and circuits, dielectric media, scattering analysis, etc. The kernel is comprehensive and has been extended for the analysis of thin dielectric sheets, multiple homogeneous dielectric bodies and planar stratified media. Hover your mouse over the different areas of the surrounding image for more information.

The new [www.feko.info](http://www.feko.info).

## Exhibitions

FEKO will be exhibited at many conferences this quarter.

|                            |                                 |
|----------------------------|---------------------------------|
| 8-12 October               | EuMW 2007 –<br>Munich, Germany  |
| 29 October<br>- 1 November | IMOC 2007 –<br>Salvador, Brazil |
| 4-9 November               | AMTA 2007 –<br>St Louis, USA    |

The knowledge base consist of two main entities:

- A help centre where content like FAQs, HOWTOs, instructional videos, and error code explanations will be posted to assist users in their work with FEKO.
- A searchable database of FEKO application notes that detail how FEKO has been used to model designs published in open literature. These application notes include full references to the original literature and FEKO models for these models that are compatible with the latest release of FEKO. These application notes and models should assist users in getting up to speed with new simulation projects much quicker than in the past.

The FEKO team invites users to browse the new site with the same login that they used for the previous website and to let us know what they think. Suggestions for more application notes or specific content will be highly appreciated.

## Comprehensive Electromagnetic Solutions

### APPLICATIONS

- Antenna Design
- Antenna Placement
- EMC Analysis
- Scattering Analysis
- Biomedical

### SOLUTION TECHNIQUES

- Method of Moments (MoM)
- Multilevel Fast Multipole Method (MLFMM)
- Finite Element Method (FEM)
- Physical Optics (PO)
- Geometrical Optics (GO)
- Uniform Theory of Diffraction (UTD)

- True hybridisation of MoM/PO and MoM/UTD
- MoM with Surface and Volume Equivalence Principle for Multiple Dielectric Bodies
- Planar Green's Functions

### FAST SOLUTIONS

- Parallel Processing
- Out-of-Core Solving
- Multi-Level Fast Multipole Method (MLFMM)

### MODEL IMPORT FORMATS

- Solid models (Parasolid, ACIS, CATIA, Pro-E, IGES, STEP, Unigraphics)
- Meshes (CADFEKO, FEMAP, NASTRAN, AutoCAD DXF, STL, PATRAN, ANSYS CDB, ABAQUS, ASCII data format, GID)

### SERVICES

- Extended Service Contract
- On-site Training (Short Course)

- CAD Preparation
- Runtime Solutions
- Engineering Consulting Services



[www.feko.info](http://www.feko.info)

